



VC-TR40_VC-TR40N RS-232 command set

No	Issue Date	Description	Apply Firmware
1	2022/11/17	First version.	VXA100
2	2024/03/07	Delete Block_Inquiry.	NA
3	2025/05/15	Add reboot command: 8x 01 DE 01 FF	VXA200
4	2025/06/30	Add Auto Trigger Zone Set/Inq	VXA201

***Notice:**

1. The RS-232 command list is for VC-TR40_VC-TR40N.
2. The yellow highlight  means the latest update.
3. The blue highlight  means the deleted item.

1. Communication Protocol

Transmit Method: Asynchronous Interface Half Duplex Serial Communication

- Transmit Speed: 9600bps or 38400bps
- Start bit: 1Bit
- Parity Check: NA
- Data Bit: 8Bit
- Stop Bit: 1Bit

2. The wire diagram

The RS232 wire diagram between presenter and remote controller as below

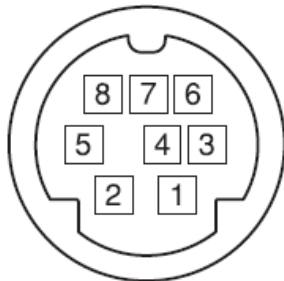

No	Pins
1	DTR IN
2	DSR IN
3	TXD IN
4	GND
5	RXD IN
6	GND

1 ACK & Completion message

	Reply Packet	Note
Ack	X0 4Y FF	Y = socket number
Completion (commands)	X0 5Y FF	Y = socket number
Completion (Inquiries)	X0 5Y ... FF	Y = socket number
X = 9 to F==>camera address + 8 , Y=1 to 2		

2 Error message

Error Packet	Description
X0 60 02 FF	Syntax Error
X0 60 03 FF	Command buffer full
X0 6Y 04 FF	Command cancelled
X0 6Y 05 FF	No socket (to be cancelled)
X0 6Y 41 FF	Command not executable
X = 9 to F==>camera address + 8, Y = socket number, Y=0 to 2, 0: Inquiry not execution	

3 Command execution cancel

	Cancel Packet	Note
Cancel	8X 2Y FF	Y = socket number
X = 1 to 7==>camera address, Y = socket number, Y=1 to 2		

4 Network Change

	Packet	Note
Address	88 30 01 FF	Always broadcasted
Network Change	X0 38 FF	
X = 9 to F==>camera address + 8		

5 IF_Clear

	Command	Reply Packet Note
IF_Clear	8X 01 00 01 FF	X0 50 FF
IF_Clear (broadcast)	88 01 00 01 FF	88 01 00 01 FF
X = 1 to 7==>camera address (For inquiry packet)		
X = 9 to F==>camera address +8 (For reply packet)		

6 Zoom Focus Position Table

	Wide end	Optical Tele end	Digital Tele end	
Zoom Position	0000	to 3558	to 3609(720p) / 3668(1080p)	
Focus Position	Far end		Near end	focus range is limited by each zoom position
	0000	to	131A	

7 AE_Iris Table

IRIS F1.6~14	Index(pq)	F Number
	0F	-
	0E	-
	0D	Close
	0C	F1.6
	0B	F2
	0A	F2.4
	09	F2.8
	08	F3.4
	07	F4
	06	F4.8
	05	F5.6
	04	F6.8
	03	F8
	02	F9.6
01	F11	
00	F14	

8 AE_Shutter Table

	Index(pq)	60/30 mode	50/25 mode
Shutter Speed	00	1/10000	1/10000
	01	1/5000	1/5000
	02	1/3000	1/3000
	03	1/2500	1/2500
	04	1/2000	1/1750
	05	1/1500	1/1250
	06	1/1000	1/1000
	07	1/725	1/600
	08	1/500	1/425
	09	1/350	1/300
	0A	1/250	1/215
	0B	1/180	1/150
	0C	1/120	1/120
	0D	1/100	1/100
	0E	1/90	1/75
	0F	1/60	1/50
	10	1/30	1/25

9 AE_Gain Table

Gain	Index(pq)	Value
	0F	+30 dB
	0E	+28 dB
	0D	+26 dB
	0C	+24 dB
	0B	+22 dB
	0A	+20 dB
	09	+18 dB
	08	+16 dB
	07	+14 dB
	06	+12 dB
	05	+10 dB
	04	+8 dB
	03	+6 dB
	02	+4 dB
	01	+2 dB
00	0 dB	

10 AE_Gain limit Table

Gain limit	Index(pq)	Value
	0F	+30 dB
	0E	+28 dB
	0D	+26 dB
	0C	+24 dB
	0B	+22 dB
	0A	+20 dB
	09	+18 dB
	08	+16 dB
	07	+14 dB
	06	+12 dB
	05	+10 dB
	04	+8 dB

11 AE_Exposure Comp. Table

Exposure Comp. (AE Level)	Index(pq)	Value(Step)	OSD Value
	0A	10	4
	09	9	3
	08	8	2
	07	7	1
	06	6	0
	05	5	-1
	04	4	-2
	03	3	-3
	02	2	-4
	01	1	-5
	00	0	-6

12 Camera RS232 Command List

Command Set	Command	Command Packet	Comments
Audio	Audio Enable	8x 01 04 68 0p FF	p: 2=On, 3=Off
	Delay Time	8x 01 04 6A 0p 0q 0r FF	Set AudioDelay Time for Internet Streaming pqr : delay time, range: A ~ 1F4 (10 ~ 500)
	Audio In	8x 01 04 6B 0p FF	p: 2=Line In, 3=Mic In
	Encode Sample Rate	8x 01 04 6D 0p FF	Select Audio Encode Sample Rate p: 0=48 kHz (AAC)
	Audio Volume	8x 01 04 6E 0p FF	p: 0 ~ A (0 ~ 10)
	Delay Enable	8x 01 04 6F 0p FF	Set AudioDelay On/Off for Internet Streaming p: 2=On, 3=Off
	Audio In	8x 01 7E 07 09 0p FF	p: 2=Line In, 3=Mic In
Auto Focus	AF Sensitivity	8x 01 04 58 0p FF	p: 1=High, 2=Middle, 3=Low
	AF Frame	8x 01 04 5C pp FF	p: 1=Auto, 2=Full Frame, 3=Center
Dig-Effect	Mirror	8x 01 04 61 0p FF	p: 2=On, 3=Off
	Flip	8x 01 04 66 0p FF	
Ethernet	DHCP	8x 01 7C 01 0p FF	

Command Set	Command	Command Packet	Comments
	IP Address	8x 01 7C 02 0p 0q 0r 0s 0t 0u 0v 0x FF	address : pq.rs.tu.vx (HEX), pq = 0~255, rs = 0~255, tu = 0~255, vx = 0~255, e.g. 192.168.100.150 => 81 01 7C 02 0C 00 0A 08 06 04 09 06 FF
	Subnet Mask	8x 01 7C 03 0p 0q 0r 0s 0t 0u 0v 0x FF	address : pq.rs.tu.vx (HEX), pq = 0~255, rs = 0~255, tu = 0~255, vx = 0~255, e.g. 255.255.255.0 => 81 01 7C 03 0F 0F 0F 0F 0F 0F 00 00 FF
	Gateway	8x 01 7C 04 0p 0q 0r 0s 0t 0u 0v 0x FF	address : pq.rs.tu.vx (HEX), pq = 0~255, rs = 0~255, tu = 0~255, vx = 0~255, e.g. 192.168.100.254 => 81 01 7C 04 0C 00 0A 08 06 04 0F 0E FF
	DNS	8x 01 7C 05 0p 0q 0r 0s 0t 0u 0v 0x FF	address : pq.rs.tu.vx (HEX), pq = 0~255, rs = 0~255, tu = 0~255, vx = 0~255, e.g. 8.8.8.8 => 81 01 7C 05 00 08 00 08 00 08 00 08 FF
Exposure	ICR	8x 01 04 01 0p FF	p: 2=ICR On(NIGHT) 3=ICR Off(DAY)
	Shutter Reset	8x 01 04 0A 00 FF	Reset Shutter Setting to the default value depending on the frame rate of Output Mode (* Available during Shutter Priority/Manual Mode)
	Shutter Up	8x 01 04 0A 02 FF	Available during Shutter Priority/Manual Mode
	Shutter Down	8x 01 04 0A 03 FF	
	Iris Reset	8x 01 04 0B 00 FF	Available during Iris Priority/Manual Mode
	Iris Up	8x 01 04 0B 02 FF	
	Iris Down	8x 01 04 0B 03 FF	

Command Set	Command	Command Packet	Comments
	Manual Gain Reset	8x 01 04 0C 00 FF	Available during AE Manual Mode
	Manual Gain Up	8x 01 04 0C 02 FF	
	Manual Gain Down	8x 01 04 0C 03 FF	
	Exposure Comp Reset	8x 01 04 0E 00 FF	Available during ExpComp On
	Exposure Comp Up	8x 01 04 0E 02 FF	
	Exposure Comp Down	8x 01 04 0E 03 FF	
	Spot Light Position	8x 01 04 29 0p 0q 0r 0s FF	pq: X-axis, 00 ~ 06 rs: Y-axis, 00 ~ 04
	Gain Limit	8x 01 04 2C 0p FF	p: 4 ~ F
	WDR	8x 01 04 2D 0p FF	p: WDR mode, 0 ~ 3
	Back Light	8x 01 04 33 0p FF	Back Light Compensation ON/OFF p: 2=On, 3=Off (* Available during Full Auto Mode)
	Mode	8x 01 04 39 pp FF	pp: 00=Full Auto, 03=Manual, 0A=Shutter Priority, 0B=Iris Priority, 5F=White Board
	Flickerless	8x 01 04 3C 0p FF	p: 0=Off, 1=50Hz, 2=60Hz
	Exposure Comp On/Off	8x 01 04 3E 0p FF	p: 2=On, 3=Off (* Disabled during Manual Mode)
	Shutter Direct	8x 01 04 4A 00 00 0p 0q FF	pq: Shutter Position, 00 ~ 10 (* Available during Shutter Priority/Manual Mode)

Command Set	Command	Command Packet	Comments
	Iris Direct	8x 01 04 4B 00 00 0p 0q FF	pq: Iris Position, 00 ~ 0D (* Available during Iris Priority/Manual Mode)
	Manual Gain Direct	8x 01 04 4C 00 00 0p 0q FF	pq: Gain Position, 00 ~ 0F
	Exposure Comp Direct	8x 01 04 4E 00 00 0p 0q FF	pq: 00 ~ 0A
	Spot Light	8x 01 04 59 0p FF	p: 2=On, 3=Off
Focus	Stop	8x 01 04 08 00 FF	Available during Manual Focus Mode
	Far (Standard Speed)	8x 01 04 08 02 FF	
	Near (Standard Speed)	8x 01 04 08 03 FF	
	Far (Variable Speed)	8x 01 04 08 2p FF	p: Speed 0 (Low) ~ 7 (High) (* Available during Manual Focus Mode)
	Near (Variable Speed)	8x 01 04 08 3p FF	p: Speed 0 (Low) ~ 7 (High) (* Available during Manual Focus Mode)
	One Push Trigger	8x 01 04 18 01 FF	One Push AF Trigger (* Available during Manual Focus Mode)
	Mode	8x 01 04 38 0p FF	p: 2=Auto Focus, 3=Manual Focus
	Mode	8x 01 04 38 10 FF	AF ON/OFF Trigger
	Direct	8x 01 04 48 0p 0q 0r 0s FF	pqrs: Focus Position, pqrs parameters are in the General Zoom Focus Table (* Available during Manual Focus Mode)
Menu	On/Off	8x 01 06 06 pp FF	Turn on/off OSD menu screen pp: 2=On, 3=Off, 10=Toggle
	Enter	8x 01 7E 01 02 00 01 FF	OSD Menu Enter
Pan Tilt	Stop	8x 01 06 01 00 00 03 03 FF	
	UpLeft	8x 01 06 01 VV WW 01 01 FF	VV: Pan Speed 0x01 (Low) ~ 0x18 (High)
	DownLeft	8x 01 06 01 VV WW 01 02 FF	WW: Tilt Speed 0x01 (Low) ~ 0x14 (High)

Command Set	Command	Command Packet	Comments
	Left	8x 01 06 01 VV WW 01 03 FF	
	UpRight	8x 01 06 01 VV WW 02 01 FF	
	DownRight	8x 01 06 01 VV WW 02 02 FF	
	Right	8x 01 06 01 VV WW 02 03 FF	
	Up	8x 01 06 01 VV WW 03 01 FF	
	Down	8x 01 06 01 VV WW 03 02 FF	
	Absolute Position	8x 01 06 02 VV WW 0Y 0Y 0Y 0Y 0Z 0Z 0Z 0Z FF	YYYY : Pan Position 0x0000 ~ 0x0990 & 0xF670 ~ 0xFFFF (Center 0000)
	Relative Position	8x 01 06 03 VV WW 0Y 0Y 0Y 0Y 0Z 0Z 0Z 0Z FF	ZZZZ : Tilt Position 0x0000 ~ 0x0510 & 0xFE50 ~ 0xFFFF (Center 0000)
	Home	8x 01 06 04 FF	Go Home Position
	Reset	8x 01 06 05 FF	Initialize Pan Tilt and back to HOME position
	Pan Tilt Limit	8x 01 06 07 00 0W 0Y 0Y 0Y 0Y 0Z 0Z 0Z 0Z FF	W: 1=Up & Right YYYY: Pan Limit Position 0x0000~0x0990 ZZZZ: Tilt Limit Position 0x0000~0x0510 W: 0=Down & Left YYYY: Pan Limit Position 0xFFFF~0xF670 ZZZZ: Tilt Limit Position 0xFFFF~0xFE50
	Limit Clear	8x 01 06 07 01 0W 07 0F 0F 0F 07 0F 0F 0F FF	W: 1=Clear Up & Right, 0=Clear Down & Left
	Pan Direction Set	8x 01 06 14 0p FF	p=0:normal;face to VC camera, handle-bar of controller control direction is the same as camera header p=1:Reverse;behind VC camera, handle-bar of controller control direction is the same as camera header

Command Set	Command	Command Packet	Comments
	PanTilt Preset Speed	8x 01 7E 03 02 0p FF	p: 0: [5 deg/sec] \ 1: [25 deg/sec] \ 2: [50 deg/sec] \ 3: [80 deg/sec] \ 4: [120 deg/sec]
	PanTilt Preset Speed	8x 01 06 20 0p FF	p: 0: [5 deg/sec] \ 1: [25 deg/sec] \ 2: [50 deg/sec] \ 3: [80 deg/sec] \ 4: [120 deg/sec]
Pan Tilt Zoom	PTZ Speed Comp	8x 01 06 1F 01 0p FF	p: 0=Off, 1=On
Picture	Sharpness Reset	8x 01 04 02 00 FF	
	Sharpness Up	8x 01 04 02 02 FF	
	Sharpness Down	8x 01 04 02 03 FF	
	Brightness Reset	8x 01 04 0D 00 FF	
	Brightness Up	8x 01 04 0D 02 FF	
	Brightness Down	8x 01 04 0D 03 FF	
	Image Mode	8x 01 04 3F 04 0p FF	p: 0=Default, 1=Custom
	Sharpness Direct	8x 01 04 42 00 00 0p 0q FF	pq: 00 ~ 0E
	Saturation	8x 01 04 49 00 00 0p 0q FF	pq: 00 ~ 0F
	Brightness Direct	8x 01 04 4D 00 00 0p 0q FF	(* Available during Image Mode = Custom mode)
	Hue	8x 01 04 4F 00 00 0p 0q FF	
	2D NR	8x 01 04 53 0p FF	p: 0=Off, 1=Level 1, 2=Level 2, 3=Level 3

Command Set	Command	Command Packet	Comments
	3D NR	8x 01 04 54 0p FF	p: 0=Off, 1=Low, 2=Type, 3=Max
	Gamma	8x 01 04 5B 0p FF	p: 0 ~ 3 (* Available during Image Mode = Custom mode)
	Freeze	8x 01 04 62 0p FF	p: 2=On, 3=Off
Power	On/Standby	8x 01 04 00 0p FF	p: 2=On, 3=Standby
	Standby Mode	8x 01 7E 01 0A 03 0p FF	p: 2=Normal Standby (Lens Tilt Down), 3=Ceiling Standby (Lens Tilt Up)
Preset	Reset	8x 01 04 3F 00 pp FF	pp: Memory Number 0x00 ~ 0x7F (* Preset address range : 0 ~ 127)
	Set	8x 01 04 3F 01 pp FF	
	Recall	8x 01 04 3F 02 pp FF	
	Reset	8x 01 04 3F 10 pp FF	pp: Memory Number 0x00 ~ 0x7F (* Preset address range: 128 ~ 255)
	Set	8x 01 04 3F 11 pp FF	
	Recall	8x 01 04 3F 12 pp FF	
System	PrivacyMode	8x 01 04 00 02 0p FF	p: 2=On, 3=Off
	Set Camera Vender model	8x 01 04 23 pp qq rr ss FF	ppqq: Vender ID = 0x0001 , rrss:Model ID = 0x0513 (Development Only)
	Baud Rate	8x 01 04 24 00 00 0p FF	p: 0=9600 bps, 1=38400 bps
	Factory Reset (Soft)	8x 01 04 3F 03 00 FF	Reset camera setting
	Factory Reset (Hard)	8x 01 04 3F 03 01 FF	Reset camera and network setting
	Initial Position	8x 01 04 75 6A 0p FF	p: 0=Last MEM, 1=1st Preset

Command Set	Command	Command Packet	Comments
	Save last memory	8x 01 06 00 01 FF	
	IR Receive	8x 01 06 08 pp FF	pp: 2=On, 3=Off, 10=Toggle
	Output Mode	8x 01 06 35 0p 0q FF	<p>pp: 07=FHD 1080P(1920 x 1080) - 60p</p> <p>pp: 09=FHD 1080P(1920 x 1080) - 50p</p> <p>pp: 0A=FHD 1080P(1920 x 1080) - 30p</p> <p>pp: 0C=FHD 1080P(1920 x 1080) - 25p</p> <p>pp: 0D=HD 720P(1280 x 720) - 60p</p> <p>pp: 0F=HD 720P(1280 x 720) - 50p</p> <p>pp: 14=FHD 1080i(1920 x 1080) - 60i</p> <p>pp: 16=FHD 1080i(1920 x 1080) - 50i</p>
	Motionless Preset	8x 01 07 01 0p FF	p: 2=On, 3=Off
	Write Camera ID	8x 01 CE aa bb cc dd ee ff gg hh ii jj kk ll FF	aa bb cc dd ee ff gg hh ii jj kk ll : Camera ID (ASCII)
	Reboot	8x 01 DE 01 FF	Set to reboot
Tracking	Tracking-Framing Control(PresetRecall)	8x 01 04 3F 02 5p FF	<p>p:</p> <p>0=Tracking/Framing On (Recall preset 80),</p> <p>1=Tracking/Framing Off (Recall preset 81)</p>
	ID Switch	8x 01 0B 00 00 00 FF	
	Auto Tracking On/Off	8x 01 0B 00 00 0p FF	p: 2=On, 3=Off
	Mode	8x 01 0B 00 01 0p FF	p: 0=Everywhere, 1=Stage, 2=Partition, 3=Auto Framing, 4=Partition Framing, 5=Center Stage
	Sensitivity	8x 01 0B 00 02 0p FF	p: 0= Low, 1=Middle, 2=High

Command Set	Command	Command Packet	Comments
	Tracking target lost time	8x 01 0B 00 03 0p FF	3s / 5s / 10s p: 0 : 3s 1 : 5s 2 : 10s
	Lost tracking target	8x 01 0B 00 04 0p FF	p: 0=PTZ Back to the center and wide, 1=Stay in the last position, 2=Back to start position.
	Head Position	8x 01 0B 00 05 0p FF	p: 0 : Low 1 : Medium 2 : High
	Tracking LED Status	8x 01 0B 00 06 0p FF	p: 2=On, 3=Off
	Center Stage	8x 01 0B 00 07 0p FF	
	Body Size/Type	8x 01 0B 02 01 0p FF	p: 0=Full Body, 1=Upper Body
	Tracking Distance	8x 01 0B 02 0B 0p FF	p: 0=12M, 1=14M
	Auto Framing On/Off	8x 01 0B 04 02 0p FF	p: 2=On, 3=Off
	Auto-Trigger Zone	8x 01 0B 03 09 0p FF	p: 2=On, 3=Off
	Auto Framing_Sensitivity	8x 01 0B 04 03 0p FF	p: Sensitivity 0 : Low 1 : Middle 2 : High

Command Set	Command	Command Packet	Comments
	Auto Framing target lost time	8x 01 0B 04 04 0p FF	3s / 5s / 10s p: 0 : 3s 1 : 5s 2 : 10s
	Tracking-Framing TYPE	8x 0B 01 04 0p FF	p: A=Auto Tracking B=Auto Framing
	Framing Size	8x 01 0B 04 05 0p FF	p: 0 : Tight 1 : Medium 2 : Wide
White Balance	Manual Red Reset	8x 01 04 03 00 FF	Available during WB Manual mode
	Manual Red Up	8x 01 04 03 02 FF	
	Manual Red Down	8x 01 04 03 03 FF	
	Manual Blue Reset	8x 01 04 04 00 FF	
	Manual Blue Up	8x 01 04 04 02 FF	
	Manual Blue Down	8x 01 04 04 03 FF	
	One Push Trigger	8x 01 04 10 05 FF	One Push WB Trigger (* Available during One Push WB Mode)

Command Set	Command	Command Packet	Comments
	Mode	8x 01 04 35 0p FF	p: 0=Auto, 1=Indoor, 2=Outdoor, 3=One Push WB, 4=ATW, 5=Manual, C=Sodium Lamp
	Manual Red Direct	8x 01 04 43 00 00 0p 0q FF	pq: 00 ~ 7F (0 ~ 127)
	Manual Blue Direct	8x 01 04 44 00 00 0p 0q FF	
Zoom	Stop	8x 01 04 07 00 FF	
	Tele (Standard Speed)	8x 01 04 07 02 FF	
	Wide (Standard Speed)	8x 01 04 07 03 FF	
	Tele (Variable Speed)	8x 01 04 07 2p FF	p=0 (Low) ~ 7 (High)
	Wide (Variable Speed)	8x 01 04 07 3p FF	
	Digital Zoom Limit	8x 01 04 26 0p FF	p: 0 (x1) ~ B (x12)
	Direct (Variable Speed)	8x 01 04 47 0p 0q 0r 0s 0t FF	pqrs: Zoom Position refer to Zoom Focus Position Table t:Speed:0~7
	Direct (Standard Speed)	8x 01 04 47 0p 0q 0r 0s FF	pqrs: Zoom Position refer to Zoom Focus Position Table

13 RS232 Inquiry Command List

Inquiry Command	Command Packet	Inquiry Packet	Comments
Audio Enable Inq	8x 09 04 68 FF	y0 50 0p FF	p: 2=On, 3=Off
Encode Sample Rate Inq	8x 09 04 6D FF		p: 0=48 KHz (AAC)
Audio Volume Inq	8x 09 04 6E FF		p: 0 ~ A (0 ~ 10)
Delay Enable Inq	8x 09 04 6F FF		p: 2=On, 3=Off
Audio Enable Inq	8x 09 7E 07 07 FF		
AF Sensitivity Inq	8x 09 04 58 FF		p: 1=High, 2=Middle, 3=Low
AF Frame Inq	8x 09 04 5C FF		p: 1=Auto, 2=Full Frame, 3=Center
Mirror Inq	8x 09 04 61 FF		p: 2=On, 3=Off
Flip Inq	8x 09 04 66 FF		
MAC Address Inq	8x 09 04 78 FF		y0 50 0a 0b 0c 0d 0e 0f 0g 0h 0i 0j 0k 0l FF
DHCP Inq	8x 09 7C 01 FF	y0 50 0p FF	p: 2=On, 3=Off
IP Address Inq	8x 09 7C 02 FF	y0 50 0p 0q 0r 0s 0t 0u 0v 0x FF	address : pq.rs.tu.vx (HEX)
Subnet Mask Inq	8x 09 7C 03 FF		
Gateway Inq	8x 09 7C 04 FF		
DNS Inq	8x 09 7C 05 FF		
ICR Inq	8x 09 04 01 FF	y0 50 0p FF	p: 2=ICR On(NIGHT)

Inquiry Command	Command Packet	Inquiry Packet	Comments
			3=ICR Off(DAY)
Spot Light Position Inq	8x 09 04 29 FF	y0 50 0p 0q 0r 0s FF	pq: X-axis, 00 ~ 06 rs: Y-axis, 00 ~ 04
Gain Limit Inq	8x 09 04 2C FF	y0 50 0p FF	p: 4 ~ F
WDR Inq	8x 09 04 2D FF		p: WDR mode, 00 ~ 03
Back Light Inq	8x 09 04 33 FF		p: 2=On, 3=Off
Mode Inq	8x 09 04 39 FF		pp: 00=Full Auto, 03=Manual, 0A=Shutter Priority, 0B=Iris Priority 5F=White Board
Flickerless Inq	8x 09 04 3C FF		p: 0=Off, 1=50Hz, 2=60Hz
Exposure Comp Inq	8x 09 04 3E FF		p: 2=On, 3=Off
Shutter Inq	8x 09 04 4A FF	y0 50 00 00 0p 0q FF	pq: Shutter Position, 00 ~ 10
Iris Inq	8x 09 04 4B FF		pq: Iris Position, 00 ~ 0D
Manual Gain Inq	8x 09 04 4C FF		pq: Gain Position, 00 ~ 0F
Exposure Comp Level Inq	8x 09 04 4E FF		pq: 00 ~ 0A
Spot Light Inq	8x 09 04 59 FF	y0 50 0p FF	p: 2=On, 3=Off
Mode Inq	8x 09 04 38 FF		p: 2=Auto Focus, 3=Manual Focus
Position Inq	8x 09 04 48 FF	y0 50 0p 0q 0r 0s FF	pqrs: Focus Position, parameters are in the General Zoom Focuss Table near end to far end
Menu Mode Inq	8x 09 06 06 FF	y0 50 0p FF	p: 2=On, 3=Off
PanTilt Preset Speed Inq	8x 09 04 75 32 FF		p: 0: [5 deg/sec] \ 1: [25 deg/sec] \ 2: [50 deg/sec] \ 3: [80

Inquiry Command	Command Packet	Inquiry Packet	Comments
			deg/sec] \ 4: [120 deg/sec]
Pan-tiltMaxSpeedInq	8x 09 06 11 FF	y0 50 ww zz FF	ww = Pan Max Speed, ww: 0x18 zz = Tilt Max Speed, zz: 0x18
Position Inq	8x 09 06 12 FF	y0 50 0w 0w 0w 0w 0z 0z 0z 0z FF	www: Pan Position 0x0000 ~ 0x0990 & 0xF670 ~ 0xFFFF (center 0000) zzzz: Tilt Position 0x0000 ~ 0x0510 & 0xFE50 ~ 0xFFFF (center 0000)
Pan Direction Inq	8x 09 06 14 FF	y0 50 0p FF	p: 0 : Normal 1 : Reverse
PTZ Speed Comp Inq	8x 09 06 1F 01 FF		p: 0=Off, 1=On
Image Mode Inq	8x 09 04 3F 04 FF		p: 0=Default, 1=Custom
Sharpness Inq	8x 09 04 42 FF	y0 50 00 00 0p 0q FF	pq: 00 ~ 0E
SaturationInq	8x 09 04 49 FF		pq: 00 ~ 0F
Brightness Inq	8x 09 04 4D FF		
Hue Inq	8x 09 04 4F FF		
2D NR Inq	8x 09 04 53 FF	y0 50 0p FF	p: 0=Off, 1=Level 1, 2=Level 2, 3=Level 3
3D NR Inq	8x 09 04 54 FF		p: 0=Off,

Inquiry Command	Command Packet	Inquiry Packet	Comments
			1=Low, 2=Type, 3=Max
Gamma Inq	8x 09 04 5B FF		Gamma p: 0 ~ 3
Freeze Inq	8x 09 04 62 FF		p: 2=Freeze On 3=Freeze Off
Power Mode Inq	8x 09 04 00 FF		p: 2=On, 3=Standby
FW version Inq	8x 09 00 02 00 03 FF	y0 50 mm nn oo pp qq rr ss FF	mmnnooppqrrss : XXXxxxx(Ascii, data range = 0x00 ~ 0x7F)
Camera Vender model Inq	8x 09 00 02 FF	y0 50 pp qq rr ss jj kk FF	ppqq: Vender ID(0001) rrss: Model ID(0513) jjjj: Rom revision(0104) kk: Maxinum socket(02)
SERIAL INQ	8x 09 02 18 FF	y0 50 aa bb cc dd ee ff gg hh ii FF	aa bb cc dd ee ff gg hh ii : Serial Number (ASCII)
Privacy Mode Inq	8x 09 04 00 02 FF	y0 50 0p FF	p: 2=Privacy Mode On 3=Privacy Mode Off
Baud Rate Inq	8x 09 04 24 00 FF	y0 50 00 0p FF	p: 0=9600 bps, 1=38400 bps
Memory Inq	8x 09 04 3F FF	y0 50 pp FF	pp: Memory number recalled last, default value(no get any recall command) pp:0x00 , pp: 0x00 To 0x7F
Initial Position Inq	8x 09 04 75 6A FF		p: 0=Last MEM, 1=1st Preset
IR Receive Inq	8x 09 06 08 FF		p: 2=On, 3=Off

Inquiry Command	Command Packet	Inquiry Packet	Comments
Output Mode Inq	8x 09 06 23 FF	y0 50 0p 0q FF	pq: 07=FHD 1080P(1920 x 1080) - 60p pq: 09=FHD 1080P(1920 x 1080) - 50p pq: 0A=FHD 1080P(1920 x 1080) - 30p pq: 0C=FHD 1080P(1920 x 1080) - 25p pq: 0D=HD 720P(1280 x 720) - 60p pq: 0F=HD 720P(1280 x 720) - 50p pq: 14=FHD 1080i(1920 x 1080) - 60i pq: 16=FHD 1080i(1920 x 1080) - 50i
Motionless Preset Inq	8x 09 07 01 FF	y0 50 0p FF	p: 2=On, 3=Off
Camera ID Inq	8x 09 7E CE FF	y0 50 aa bb cc dd ee ff gg hh ii jj kk ll FF	aa bb cc dd ee ff gg hh ii jj kk ll : Camera ID (ASCII)
FW version Inq - Main	8x 09 7E CF FF	y0 50 mm nn oo pp qq rr ss tt FF	mmnnooppqrrsstt : XXXXxxxxx
Tracking-Framing CTRL Inq	8x 09 04 3F 02 FF	y0 50 0p FF	p: 0x02 Tracking/Framing On 0x03: Tracking/Framing Off
Tracking Auto Inq	8x 09 0B 00 00 FF		p: 02(On), 03(Off)
Tracking Mode Inq	8x 09 0B 00 01 FF		p: 0=Everywhere, 1=Stage, 2=Partition, 3=Auto Framing, 4=Partition Framing, 5=Center Stage
Tracking Sensitivity Inq	8x 09 0B 00 02 FF		p: 0 : Low 1 : Middle 2 : High
Tracking target lost time Inq	8x 09 0B 00 03 FF		p: 0 : 3s 1 : 5s

Inquiry Command	Command Packet	Inquiry Packet	Comments
			2 : 10s
Lost tracking target Inq	8x 09 0B 00 04 FF		p: 0 : PTZ Back to the center and wide. 1 : Stay in the last position. 2 : Back to start position.
Head Position Inq	8x 09 0B 00 05 FF		p: 0 : Low 1 : Medium 2 : High
Tracking LED Status Inq	8x 09 0B 00 06 FF		p: 2=On, 3=Off
Center Stage Inq	8x 09 0B 00 07 FF		p: 2=On, 3=Off
Tracking Body Size Inq	8x 09 0B 02 01 FF		p: 0 : Full Body 1 : Upper Body
Tracking Distance Inq	8x 09 0B 02 0B FF		p: 0=12M, 1=14M
Auto-Trigger Zone	8x 09 0B 03 09 FF		p: 2=On, 3=Off
People Count Inq	8x 09 0B 04 01 FF	y0 50 0p 0q 0r 0s FF	pqrs: people count value
Framing CTRL Inq	8x 09 0B 04 02 FF		p: 2=On, 3=Off
Auto Framing Sensitivity Inq	8x 09 0B 04 03 FF	y0 50 0p FF	p: Sensitivity 0 : Low 1 : Middle 2 : High
Auto Framing target lost time Inq	8x 09 0B 04 04 FF		p: 0 : 3s 1 : 5s

Inquiry Command	Command Packet	Inquiry Packet	Comments
			2 : 10s
Framing Size	8x 09 0B 04 05 FF		p: 0 : Tight 1 : Medium 2 : Wide
Tracking-Framing TYPE Inq	8x 09 0B 04 FF		p: 0x0A : Auto Tracking 0x0B : Auto Framing
Mode Inq	8x 09 04 35 FF		p: 0=Auto, 1=Indoor, 2=Outdoor, 3=One Push WB, 4=ATW, 5=Manual, C=Sodium Lamp
Manual Red Inq	8x 09 04 43 FF	y0 50 00 00 0p 0q FF	pq: 00 ~ 7F (0 ~ 127)
Manual Blue Inq	8x 09 04 44 FF		
Position Inq	8x 09 04 47 FF	y0 50 0p 0q 0r 0s FF	pqrs: Zoom Position, Min. 0000h Max. 4000h (In Dzoom Limit = x1) Max. 7AC0h (In D-Zoom Limit = x2 ~ 12x)

14 RS232 over IP

14.1 Overview of RS232 over IP

RS232 over IP allows you to control this unit from the controller with the IP communication function via the LAN by using RS232.

You can connect up to 5 controllers simultaneously on one LAN segment.

The communication specifications of RS232 over IP are as follows:

14.2 Interface

RJ-45 10Base-T/100Base-TX (automatically discrimination)

14.3 Internet protocol

IPv4

14.4 Transport protocol

UDP

14.5 IP address

Set by the IP card setting command

14.6 Port address

52381

14.7 Delivery confirmation/Retransmission control

Depends on the application

14.8 Coverage

Limited dedicated network in the same segment without going through a bridge connection.

In this section, the device outputting commands, for example, a computer, is called the controller, and this unit and the devices connected to the same LAN are called the peripheral device. In the connection using RS-232/RS-422, the controllers and peripheral devices are connected to a one-direction ring. On the IP communication connection, the controllers and peripheral devices are connected by star type through a LAN.

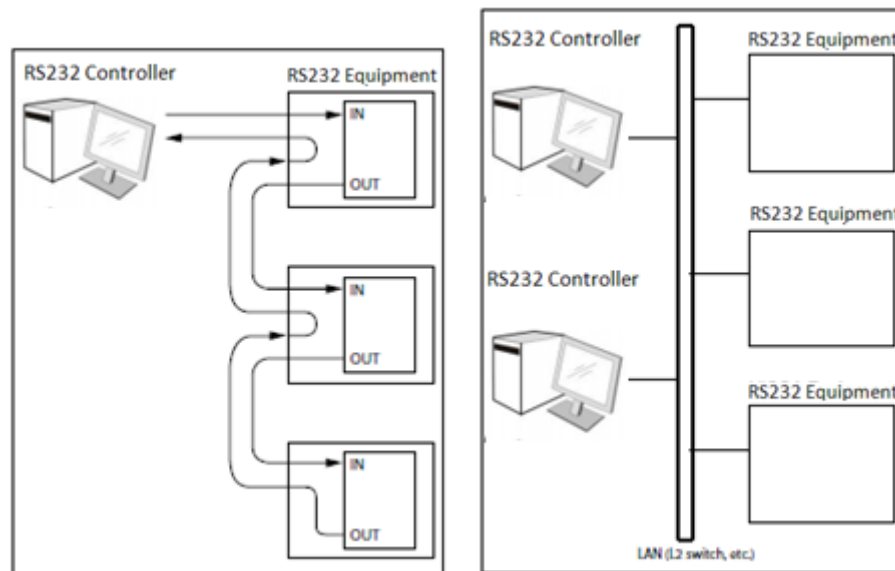

RS232/RS422 connection

IP communication connection

While the IP communication connection, the address of each device cannot be set in the RS232 message as it is because the controllers and peripheral devices that are connected simultaneously are increased. In this case, addresses of the controllers and peripheral devices that are set in the RS232 message are locked to 0 (for the controller) or 1 (for the peripheral device).

14.9 Packet Structure

The basic unit of VISCA communication is called a packet [Pic.1]. The first byte of the packet is called the header and comprises the sender's and receiver's addresses. For example, the header of the packet sent to the SRG assigned address 1 from the controller (address 0) is 81h in hexadecimal. The packet sent to the SRG assigned address 2 is 82h. In the command list, as the header is 8X, input the address of the SRG to X. The header of the reply packet from the SRG assigned address 1 is 90h. The packet from the SRG assigned address 2 is A0h.

Some of the setting commands for SRG can be sent to all devices at one time (broadcast)*. In the case of broadcast, the header should be 88h in hexadecimal.

When the terminator is FFh, it signifies the end of the packet.

*The broadcast function is not available for VISCA over IP.

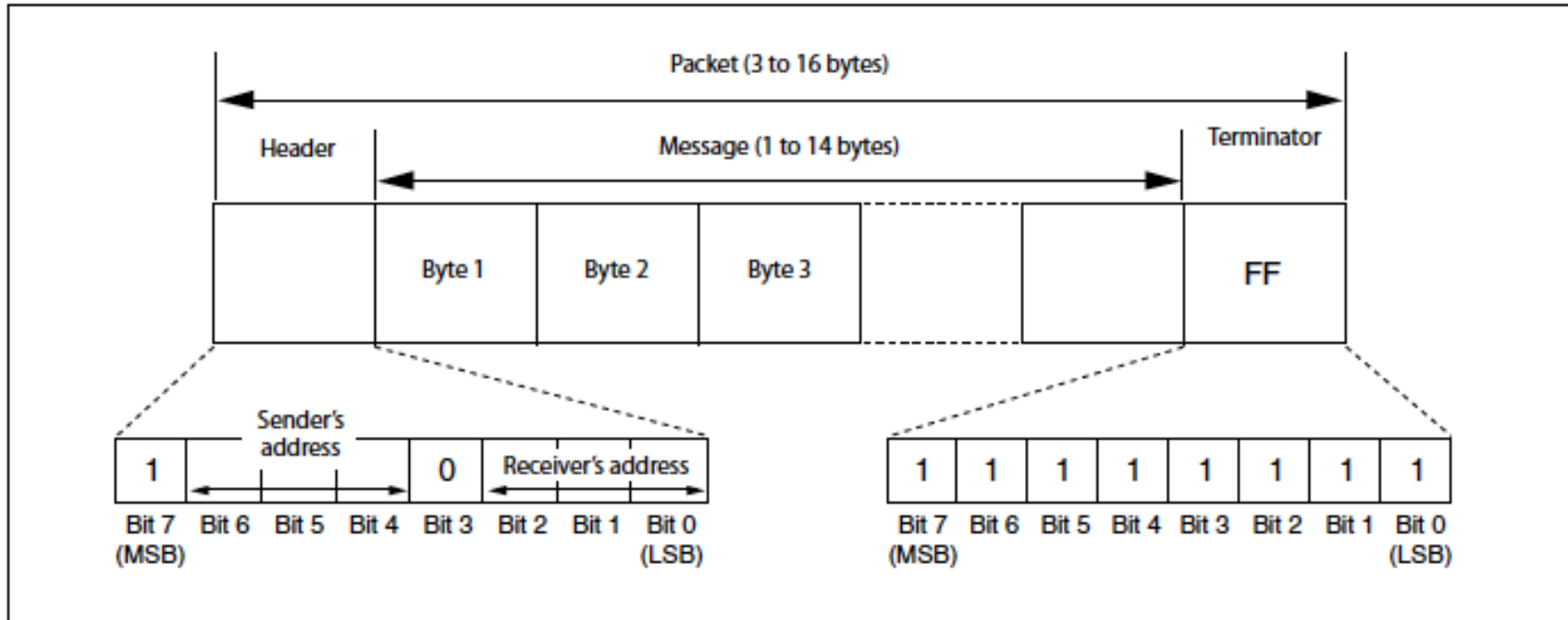

Pic. 1 Packet structure

Note:

Pic. 1 shows the packet structure, while Pic.2 shows the actual waveform. Data flow will take place with the LSB first.

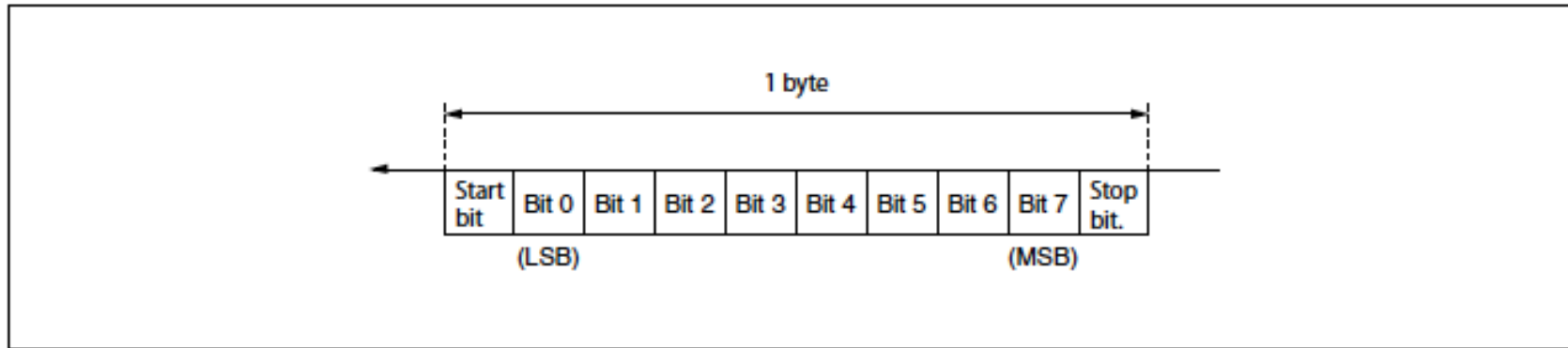

Pic. 2 Actual waveform for 1 byte

15 Communication method of VISCA over IP

15.1 Communication method

VISCA over IP can process the VISCA communication between the controllers and peripheral devices using the messages that can be identified on the LAN, and sends/receives them. Because of this, VISCA over IP is not concerned about the contents of the communication between the controllers and peripheral devices. However, the VISCA communication sequence is different, depending on the types, as follows.

15.2 VISCA command

This is a command from the controller to the peripheral device. When the peripheral device receives this command, Acknowledge is returned. After completing command processing, a completion notice is returned. This command uses the socket of VISCA. The order of completion notices may be changed if the multiple commands are sent to the same peripheral device.

15.3 VISCA inquiry

This is an inquiry from the controller to the peripheral device. When the peripheral device receives this type of command, the reply for the inquiry is returned. This command does not use the socket of VISCA. The order of the replies is not changed if a multiple commands are sent.

15.4 VISCA reply

This is an Acknowledge, completion notice, reply, or error reply from the peripheral device to the controller. The classification for sending messages from the peripheral device to the controller is common.

15.5 VISCA device setting command

This is the device setting command from the controller to the peripheral device. When the peripheral device receives this classifications command, the peripheral device performs the function depend on the command.

15.6 Address

Sets the address of the peripheral device, and does not return a reply to the controller. While using VISCA over IP, the address command is not sent from the controller because a Network Change command from the peripheral device that triggers sending command is not issued.

15.7 IF_Clear

Sends the reply message to the controller after clearing, without using VISCA socket.

15.8 CAM_VerslonInq

Sends the reply message to the controller, without using VISCA socket.

15.9 Format

These are the specifications of the message header (8 bytes) and payload (1 to 16 bytes).

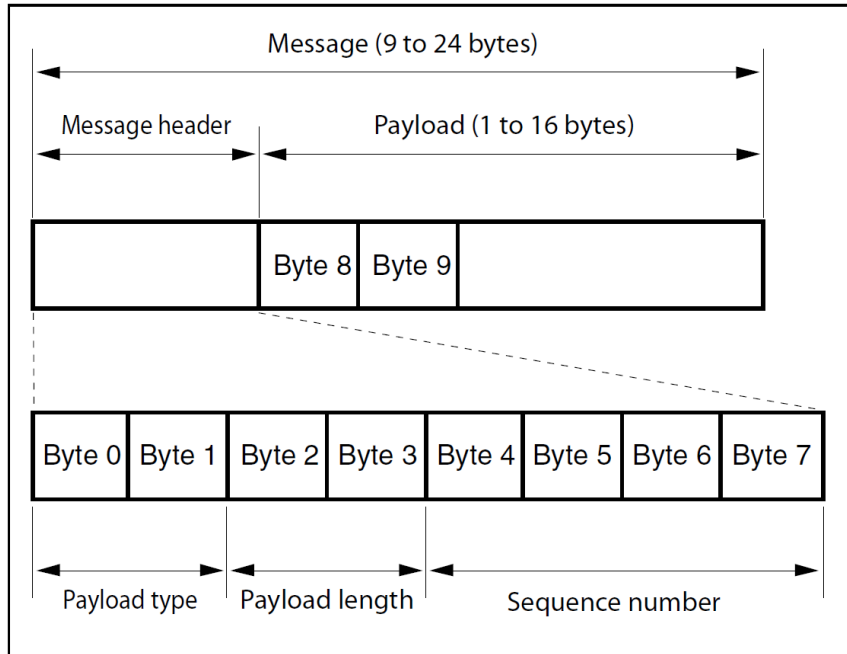

Note: The actual LAN out method is big-endian, LSB first.

Pic.3 Message structure of the VISCA over IP

Example:

Command	Payload type		Payload length		Sequence number				Payload (1~16Byte)										
	Byte 0	Byte 1	Byte 2	Byte 3	Byte 4	Byte 5	Byte 6	Byte 7	Byte 1	Byte 2	Byte 3	Byte 4	Byte 5	Byte 6	Byte 7	Byte 8	Byte 9	...	Byte 16
CAM_Power On	01	00	00	06	00	00	00	01	81	01	04	00	02	FF					
Pan-tiltDrive Up	01	00	00	09	00	00	00	02	81	01	06	01	0C	0C	03	01	FF		
Pan-tiltDrive Down	01	00	00	09	00	00	00	03	81	01	06	01	0C	0C	03	02	FF		
CAM_FocusModeInq	01	10	00	5	00	00	00	04	81	9	4	38	FF						

15.10 Payload type

Stores the value (Byte 0 and Byte 1) of the following table on the payload division.

Name	Value (Byte 0)	Value (Byte 1)	Description
VISCA command	01h	00h	Stores the VISCA command.
VISCA inquiry	01h	10h	Stores the VISCA inquiry.
VISCA reply	01h	11h	Stores the reply for the VISCA command and VISCA inquiry, or VISCA device setting command.
VISCA device setting command	01h	20h	Stores the VISCA device setting command.
Control command	02h	00h	Stores the control command.
Control reply	02h	01h	Stores the reply for the control command.

Pic.4 Payload Type Table

15.11 Payload length

Stores the number of bytes (1 to 16) of data is stored on the payload.

Example: when the payload length is 16 bytes.

Byte 2:00h

Byte 3:10h

15.12 Sequence number

The controller stores the sequence number that is added every time a message is sent. If the sequence number reaches the limit, next values will be 0. The peripheral device saves the sequence number in the message from the controller, and stores the sequence number of the received message corresponding to the message sent to the controller.

15.13 Payload

Depending on the payload type, the following are stored.

- VISCA command
 - Stores the packet of the VISCA command.
- VISCA inquiry
 - Stores the packet of VISCA message.
- VISCA reply
 - Stores the reply for the command or inquiry (Acknowledge message, completion message, or error message).

- VISCA device setting command
 - Stores the packet of the VISCA device setting command.
- Control command
 - The following are stored on the payload division of the control command.

Name	Value	Description
RESET	01h	Resets the sequence number to 0. The value that was set as the sequence number is ignored.
ERROR	0Fyyh	yy=01: Abnormality in the sequence number.
		yy=02: Abnormality in the message (message type)

- Controlled reply
 - The following are stored on the payload division of the reply for the control command.

Message	Value	Description
Acknowledge	01h	Reply for RESET.

15.14 Delivery confirmation

VISCA over IP uses UDP as a communications protocol of the transport layer. Delivery of messages is not guaranteed for the UDP communication. Delivery confirmation and retransmission should be performed on the application.

When the controller sends a message to the peripheral device, wait until a reply for the message is received before sending the next message. You can confirm delivery of messages by managing the time-out waiting for a reply message sent.

If time out occurs on the controller, loss of one of the following message is considered:

- Command
- Acknowledge message

- Completion message for command
- Inquiry
- Reply message for the inquiry
- Error message
- Inquiry of the VISCA device setting command
- Reply message of the VISCA device setting command.